



HIRT kinetics® Ascending



Applications

Patented descending windows from HIRT moving architecture® have been successfully used for many years as thermally insulated elements in the external envelopes of buildings. This system offers several key advantages: The panels can be raised vertically behind a fixed element, freeing up space that can be used and designed as you wish. Energy costs are reduced by the combination of effective ventilation and an excellent thermal insulation rating.

The window can be inserted as a prefabricated unit into masonry or wood framed openings as well as integrated into a modern glass façade. HIRT kinetics® Ascending can be used at office, residential, food-service, and school settings, or anywhere else where this space-saving feature is an asset.

Safety

We do not compromise in terms of safety. If a chain breaks, the proprietary restraint feature reacts immediately, guaranteeing the safety of people and property. HIRT kinetics® Ascending conforms to the highest safety standards.

Operation and drive mechanism

The window is moved up and down either manually (with an ordinary lift handle) or automatically. We supply and install the motor, controls and other components needed for automatic operation. The basic model includes a “deadman” feature that allows opening and closing only when the switch is pressed and held.

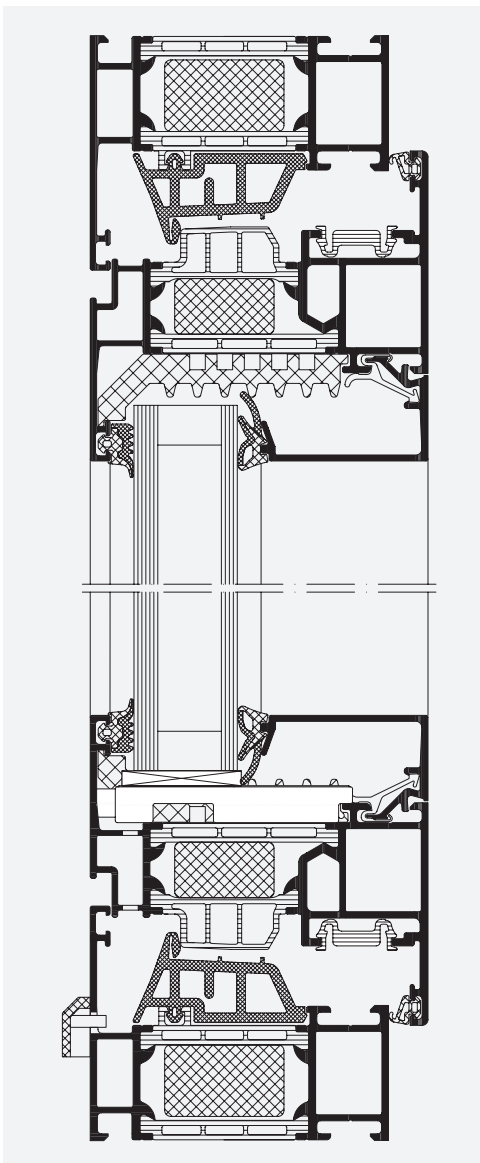

Functional principle

The sash is suspended on chains with counterweights. High-quality ball bearings in the frame run silently. The tracks with integrated mechanism are mounted to the frame section and lie flush against the sash in order to save space. The profile view is thus elegantly slender. Aesthetically pleasing aluminum cladding conceals the mechanisms, suspension and counterweights. The counterweight size is optimized to the weight of each sash.

Electrical power and control (automated models only)

The builder is responsible for the wiring of the motors, limit switches, control boxes and line power receptacles to be provided by an electrician. We supply conduit routing data, conductor sizes, motor power ratings and wiring diagrams. Our microprocessor control system combines adaptable modern technology. Options, such as remote control, safety edge switches, electric eyes, automatic sensors, etc., can be integrated without difficulty.

Maintenance

The system is designed to state-of-the-art standards, with high-quality components that minimize malfunctions and require the least possible maintenance. Periodic inspections of the mechanisms and safety elements as provided in the guidelines can be covered by a service agreement to guarantee trouble-free operation and value retention.



Temperature progression

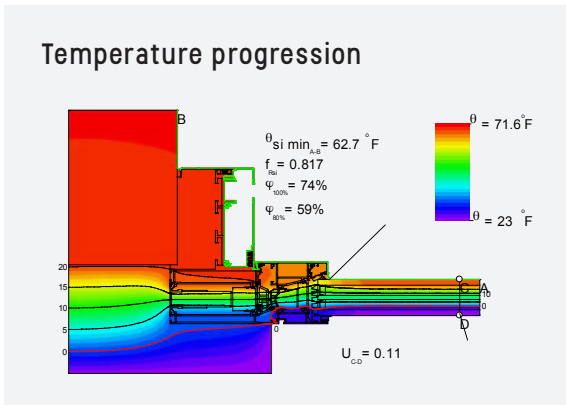

Isothermal progression

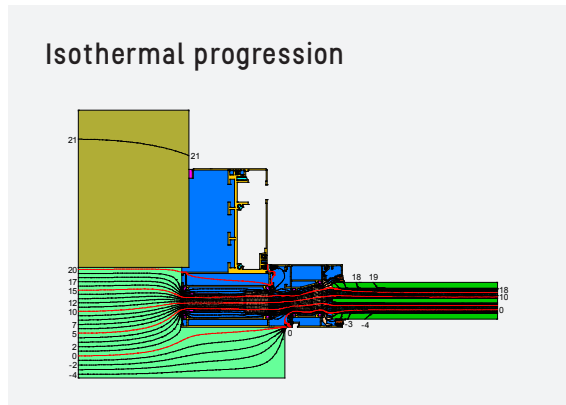

Physical properties

The thermal and acoustic insulation ratings are governed by the window system used. Most current systems can be fitted. Flush sashes, integral systems and others can be installed in the vertically sliding system. Finishes include insulated aluminum, steel and stainless steel.

Schüco AWS 75.SI+ Tests and Standards*

Thermal insulation according to EN ISO 1077-2	$U_f = 0.16-0.25$
Sound insulation according to EN ISO 140-3	to Rw48 dB
Air permeability according to EN 12207	Class 4
Rain impermeability according to EN 12208	Class 9A

* HIRT kinetics® HF fittings can be combined with various system profiles; the specifications above are quoted as a guideline.

Maximum sizes

The standard version is good for sashes up to a maximum size of 13 ft wide and 8 ft high (maximum 65 ft²) and a maximum weight of approx. 650 lbs. Static modifications to the sashes, tracks, suspensions and other components are required for larger sizes. Please inquire about larger sizes or customizations.

Installation arrangements

Vertically sliding windows can be installed in all types of façades: double-shell masonry walls, solid walls with external insulation, externally cladded walls with rear ventilation and modern glass-and-metal façades. Casings are to be used as needed.

Goldbrecht LLC

5701 Buckingham Pkwy
Culver City, CA 90230

Tel. +310 988 4455 | info@hirtUSA.com

www.hirt.swiss

